

Model 4262
Twin UCA
Operating Manual

Revision AA – March 2016
P/N 84-0005

S/N _____



Поставщик: ЗАО "ТЕХИМПОРТ"
Адрес: 614007, г. Пермь, ул. 25 Октября 72, офис 40
Телефон: +7 (342) 262-85-56
Факс: +7 (342) 262-85-60
email: office@techimport.ru
www.techimport.ru

Copyright © 2016, by Chandler Engineering Company, LLC
All rights reserved. Reproduction or use of contents in any manner is prohibited without express permission from Chandler Engineering Company L.L.C.
While every precaution has been taken in the preparation of this manual, the publisher assumes no responsibility for errors or omissions. Neither is any liability assumed for damages resulting from the use of the information contained herein.

This publication contains the following trademarks and/or registered trademarks: AMETEK, CHANDLER ENGINEERING. These trademarks or registered trademarks and stylized logos are all owned by AMETEK, Inc. All other company, product and service names and logos are trademarks or service marks of their respective owners.

Table of Contents

	<u>Page</u>
General Information.....	P-1
Description of Instrument	P-1
Features	P-1
Instrument Specifications	P-1
Section 1 - Installation.....	1-1
Unpacking the Instrument	1-1
Utility Requirements	1-1
Tools/Equipment Required	1-1
Safety Requirements	1-1
Setting up the Instrument	1-2
Connecting Power	1-2
Connecting Water Supply Lines	1-2
Connecting the Drain Lines	1-3
Connecting Air to Instrument	1-3
Section 2 – Operating Instructions	2-1
Front Panel Controls	2-1
Pump Pressure Adjust Regulator	2-1
Pump Pressure Gauge	2-2
Pressure Relief Valve	2-2
Pump Switch	2-2
Pressure Valve Left/Right	2-2
Cooling Water Switch Left/Right	2-2
Pressure Release Valve	2-2
Cylinder Pressure Gauge Left/Right	2-3
Temperature Controller Left/Right	2-3
Heater Switch Left/Right	2-3
Main Power Switch	2-3
Top Transducer Connector	2-3
J Thermocouple Connector	2-3
Rear Instrument Panel	2-4
Main Power Connection	2-4
Serial RS232/RS485 Connections	2-4
Preparing the Instrument for a Test	2-5
Programming the Temperature Controllers	2-5
Setting Up the Test Cell.....	2-5
Preparing the Test Cell	2-6
Running a Test	2-7
Pressure Control	2-7
Starting the Test	-

Ending the Test	2-8
Cleaning the Test Cell.....	2-8
Section 3 - Maintenance and Servicing	3-1
Maintenance	3-1
7 Micron Filter Replacement	3-1
Regulator Rebuild Instructions	3-1
Major Disassembly	3-2
Bonnet Disassembly/Reassembly	3-2
Sensor Disassembly / Reassembly	3-2
Major Assembly	3-3
Section 4 - Troubleshooting Guide.....	4-1
Section 5 – Replacement Parts	5-1
Section 6 - Drawings and Schematics.....	6-1

General Information

Description of Instrument

The 4262 Ultrasonic Cement Analyzer is an instrument that is used to test a cement sample at elevated temperature and pressure for the purpose of predicting compressive strength of the cured cement.

Features

The major features of the 4262 Ultrasonic Cement Analyzer are listed below:

- Easy to install and use
- Compact, bench top design
- Twin cells for conducting two simultaneous tests
- Interface to Chandler Engineering 5270 Data Acquisition System
- Ramp and Soak temperature controllers
- Integral pump and relief valve for pressure control.

Instrument Specifications

- **Maximum Curing Temperature:** 400°F (204°C)
- **Maximum Curing Pressure:** 5,000 psi (35 mPa)

Mechanical and Electrical

- **Input Voltage:** 220 ±15% VAC, 50/60 Hz, 8A.
- **Heater:** Four heaters at 350 W each

Environmental and Utility

- **Operating Temperature:** 40-120°F (0-50°C)
- **Compressed Air:** 75-125 psi (618 to 963 kPa)
- **Pressurized Water:** 20-80 psi (138 to 552 kPa)

This page is intentionally left blank.

Section 1 - Installation

Unpacking the Instrument

After the consistometer is unpacked, the operating equipment and spare parts on the packing list should be checked to affirm that all have been received and none are damaged.

File an insurance claim with your freight carrier if damage has occurred during shipment.

Utility Requirements

Your unit will require dry, oil free compressed shop air (not instrument quality) of 75 to 125 psi (618-963 kPa), and a water supply of 20-80 psi (138-552 kPa). The unit is capable of operating in ambient temperatures from 40°F to 120°F.

Tools/Equipment Required

A standard maintenance or mechanics tool set is adequate for the installation, operation, and maintenance of the instrument. No special tools are required.

This unit is supplied with an installation kit, which includes the necessary hardware for the water, air, and electrical hook-ups. The water and air hose may be cut to length and the appropriate barbed fittings inserted into the hose and clamped into place.

Caution: The laboratory electrical power wiring must be capable of a 15-ampere load and comply with local electrical codes. The instrument must be securely connected to an appropriate earth ground. The ground wire must have a larger diameter than that of the supply voltage conductors.

Safety Requirements

*Warning: **Read before attempting operation of instrument.***

This instrument is capable of extremely high temperatures and pressures and must always be operated with CAUTION. The instrument is designed for operator safety. To ensure of that safety it is essential to follow the instructions outlined below.

The following safety procedures are advisable:

- Locate the instrument in a low traffic area.
- Post signs where the instrument is being operated to warn other personnel.
- Read and understand the instructions and caution notes before attempting operation.
- Always close the pressure valve before disconnecting the quick-connect fitting to prevent water from being forced out and spraying directly on operator.

- Never exceed instrument maximum pressure and temperature ratings. Disconnect the main power to the instruments during service or repair operations.
- Always operate instrument with back panel in place.
- Turn off the heater at the completion of a test. Hot water in the open cylinder or drain, when exposed to the atmosphere and heated beyond its boiling point, can cause severe burns from steam.
- During a test the enclosure, especially the area around test cells, can become extremely hot and cause injury
- A fire extinguisher, type 8 BC, should be located within 50 feet (15 meters) of the instrument.
- Have the safety officer at your location or laboratory review the safety aspects of the instrument and installation and approve the operational and installation procedures.

Setting up the Instrument

Connecting Power

The 4262 instruments have one connection for input power. Connect power to the instrument using the cord supplied with the instrument. Connect each individual instrument to a separate circuit breaker or fuse. (A 15 Amp fuse or circuit breaker is recommended.)

Connecting Water Supply Lines

All fittings on the instruments' back panel are 1/4" female N.P.T. The included accessories kit contains the hose connectors necessary for installation.

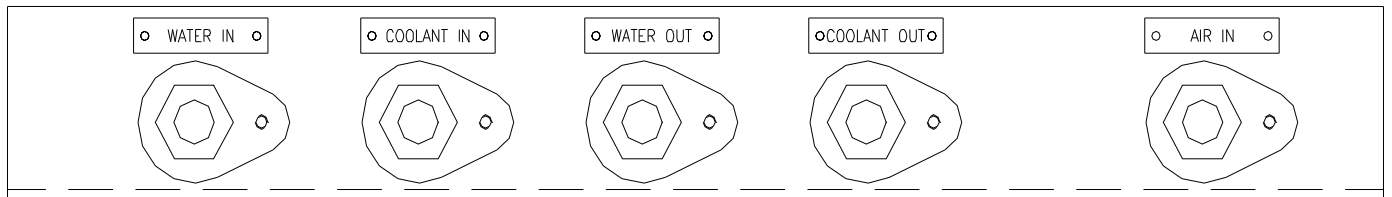

Refer to *84-0006 Plumbing Schematic*, found in *Section 6 – Drawings and Schematics*, for suggested plumbing hook-ups.

Connect the water supply line to the connector labeled WATER IN and COOLANT IN on the rear panel of the instrument. The water must be clean and free of debris that could cause failure of the pump or relief valve. A coarse water filter is supplied in the installation kit. If in doubt, an additional water filter is recommended.

If the optional chiller is being used, connect the outlet port of the chiller system to the COOLANT INLET port and the COOLANT DRAIN port to the chiller inlet port. Configure the chiller to operate at the minimum set-point temperature (41°F, 5°C).

Connecting the Drain Lines

Connect the water drain line to the connector labeled WATER OUT and COOLANT OUT on the rear panel of the instrument.

The drain system must be capable of handling hot water up to 212°F (100°C) or brief surges of up to 400°F (204°C) steam for short periods of time during initial cooling of the instrument. If two or more instruments are connected to a common drain line, it is recommended that the common drain be 3/8-inch (10mm) inside diameter, minimum.

Note: Do not discharge ethylene glycol solutions into the drain since it is considered an environmentally harmful substance. Dispose of used solutions as recommended according to the M.S.D.S.

Connecting Air to Instrument

Connect the air supply to the connector labeled AIR INLET on the rear panel of the instrument as shown in the preceding figure. The fitting is a 1/4-inch female N.P.T. fitting. Compressed nitrogen may also be used in place of the compressed air if necessary.

This page is intentionally left blank.

Section 2 – Operating Instructions

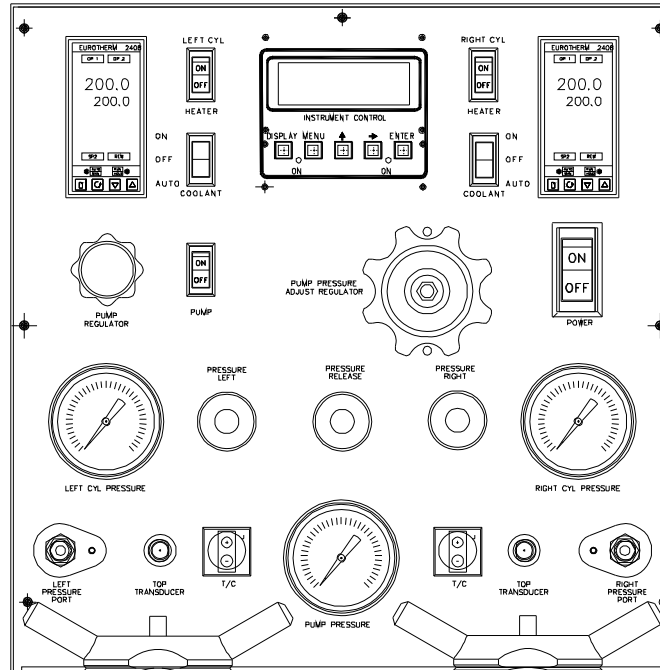

Front Panel Controls

The figure above shows the front panel and all the associated controls. The description of each control is described below.

Pump Pressure Adjust Regulator

This regulator is used to control the pressure of the air supplied to the pump, which is directly proportional to the hydraulic pressure output of the pump. As the air pressure increases, the hydraulic pressure increases. Turn the regulator knob counterclockwise to decrease air pressure to the pump, clockwise to increase the air pressure.

If the regulator is set to a value and the pump switch is turned to the ON position, the pump will increase pressure until the pneumatic force of the air (air pressure multiplied by pneumatic piston area) equals the hydraulic force of the pressurizing water (water pressure multiplied by pump piston area). At this point the pump will cease to stroke. If the water pressure falls for some reason, a force imbalance will be created between the pneumatic and hydraulic sides of the pump and the pump will begin to stroke and increase the hydraulic pressure until it is balanced with the pneumatic pressure, then it will again stop pumping. In this way, the pump may be used as a pressure control device (combined with the relief valve) to establish the lower pressure limit for a test. This will be discussed further in the section *Running a Test*.

Pump Pressure Gauge

Indicates the pressure of the water supplied from the pump. May be changed, as discussed in the paragraphs above. Each 5 psig (35.5 kPa) pressure applied to the pump results in approximately a 355 psi (2450 kPa) hydraulic pressure output from the pump.

Pressure Relief Valve

The relief valve or back-pressure regulator may be used to set the upper limit on the system pressure up to 5,000 psig. Turn the relief valve knob clockwise to increase pressure and counterclockwise to reduce pressure. The use of the pump and relief valve to control pressure automatically will be discussed in the section titled *Running a Test*.

Pump Switch

Opens or closes a solenoid valve which controls the flow of air to the pump. Turning this switch to the ON position causes the pump to maintain or increase pressure in the test cell. Turning the switch to the OFF position stops the pump from operating.

Pressure Valve Left/Right

This valve is used to control the flow of water from the pump and test cell and must be closed any time the test cell is not installed. The valve must be open to fill the tubing connected to the test cell with water or to operate the pump. Opening this valve when the test cell is not installed will cause a significant water leak.

Caution: Close the valve before disconnecting the quick-connect fitting to prevent water from being forced out and spraying directly on operator.

Cooling Water Switch Left/Right

This valve is used to control the flow of cooling water to the heating/cooling jacket. This switch must be off during a test, but should be opened following a test to cool the heater and test cell. With the Auto Cooling option, this switch can be set to Auto to allow the temperature controller to control the coolant valve. This is useful for tests where the sample must be below ambient temperature.

Pressure Release Valve

The valve must be closed during testing except when it is necessary to manually release pressure. The valve must also be closed when removing test cell with cooling water ON or else a significant water leak will occur.

Cylinder Pressure Gauge Left/Right

Displays pressure inside the test cell.

Temperature Controller Left/Right

Controls temperature inside the test cell.

Heater Switch Left/Right

Turns the heater ON or OFF. Switch must be in the ON position during testing and should be in the OFF position as a safety precaution at other times.

Main Power Switch

Turns power to the entire instrument ON or OFF. Switch must be in the ON position during testing.

Top Transducer Connector

The coaxial connector attached to the top transducer must be connected to this connector prior to the beginning of a test.

J Thermocouple Connector

The thermocouple that is attached to the top plug must be plugged into this connector prior to the beginning of a test and any time that it is necessary for the temperature controller to operate. If the thermocouple is not connected, the temperature will display **5.br** and will not function.

Rear Instrument Panel

The rear panel contains all the connections for the cables that connect the instrument to the processor.

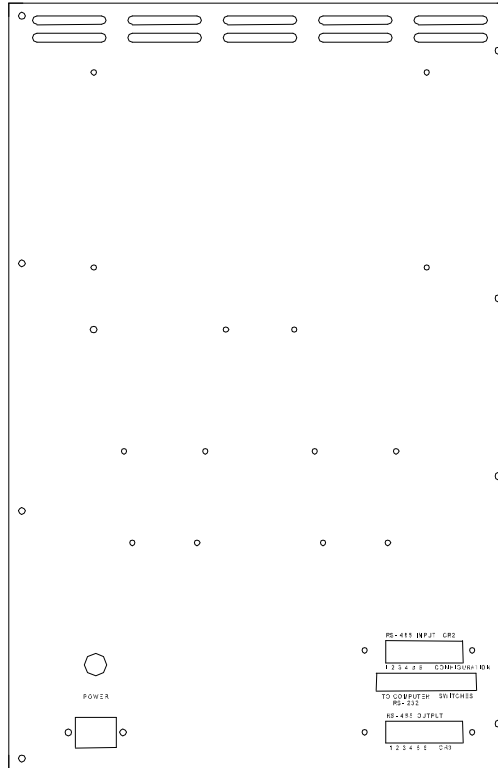

Main Power Connection

Located on the rear instrument panel is an IEC-320 STD C13 connector.

Serial RS232/RS485 Connections

The rear panel contains all of the connections for the RS-485/RS-232 communications ports used to connect several instruments in one 4262 UCA System.

Preparing the Instrument for a Test

Prior to running a test, the following steps must be performed.

Programming the Temperature Controllers

Refer to the Chandler Engineering Model 8050 Temperature Controller Manual for complete information on how to program and operate the temperature controller.

Setting Up the Test Cell

The steps that should be used to set up the test cell are listed below.

Warning: The plugs and vessels are not interchangeable without voiding the pressure vessel certification. Any replacement of the top plug, bottom plug, or vessel, requires a new hydrostatic test certification.

Note: If cement sets in the threads during a test, the plug may be extremely difficult to remove.

- Replace the O-ring seals on the top and bottom plugs after each test. The brass back-up ring must be on the side of the O-ring closest to the threads on the plug (see drawing 84-0045).
- Always double-check the sealing components to make sure they are clean and in good condition.
- Apply a light coating of lithium grease to the inside cylinder and threads and also to each plug. This will prevent cement from sticking to the metal and will make cleanup easier. Avoid applying grease on the flat face of the plugs, as they will affect the transducer signal.

The test cylinder is tapered from top to bottom, with the smallest diameter at the top. This is to facilitate removal of the cement sample from the test cell. The top of the cylinder is denoted by the letter “T” stamped on the wrench flat on the top end of the cylinder.

- Place the cylinder in a vise with the bottom end up using the wrench flats on either end of the cylinder. Use caution when placing the cylinder in the vise and do not damage the cylinder by tightening the vise excessively, or clamp the cylinder any place other than the flats on either end of the cylinder.
- Make certain the sealing components are properly installed on the bottom plug. Apply a liberal coating of high temperature grease on the o-ring.

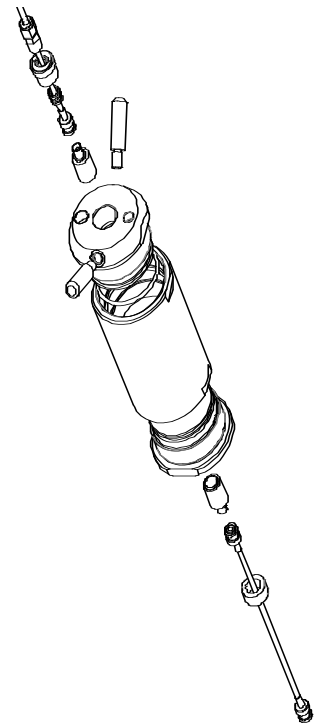

- Screw the bottom plug into the bottom of the cylinder. It is important that the plug be tightened so that it just contacts the top of the cylinder. Further tightening after the plug has contacted the cylinder will not cause more effective sealing and will cause plug removal difficulty, as well as severe damage to the cylinder and end caps.

Preparing the Test Cell

The recommended steps in preparing the test cell and slurry for testing are outlined in the following steps.

- Pour approximately 200cc of cement slurry into the greased test cell. Be careful not to get cement into the threads. If cement sets up in the threads it may make plug removal and installation difficult.
- Continue to pour cement into the test cell until level is 1/4 inch (6mm) below the circular lip in the cylinder. Alternately, you can use the Slurry Level gauge provided with the instrument. The slurry should touch the lower tab marked WET but not touch the upper tab marked DRY. Do not overfill the test cell or cement will be forced into the pressure and/or thermocouple ports and will plug them.
- Pour a small amount of water into the cylinder on top of the cement--just enough to reach the water fill line on the Slurry Level Gauge.
- Make certain the sealing components are properly installed on the bottom plug. Apply a liberal coating of high temperature grease on the o-ring and back-up ring.
- Screw the top plug in place. It is important that the plug be tightened so that it just contacts the top of the cylinder. Further tightening after the plug has contacted the cylinder will not cause more effective sealing and will cause plug removal difficulty, as well as severe damage to the cylinder and end caps. A small amount of water should come out of the pressure or thermocouple port when the top plug is in place. This is very important in that it shows that all the air has been removed from the cylinder.
- Connect the top sensor cable to the connection labeled TOP TRANSDUCER left/right. The transit time should be between 14.5 and 17.0 micro-sec/inch at the beginning of a test with pressure on the cell.
- Coat the top and bottom transducer surface with the couplant gel supplied in the accessory kit.
- Connect the thermocouple cable to the connector labeled "T/C."
- Install the thermocouple into the remaining high-pressure port in the top plug of the test cell until the fitting is finger tight.
- Slowly open the pressure valve left/right until water begins to come out the thermocouple connection vent hole. Quickly tighten the thermocouple with a 5/8" open-end wrench. It is recommended a rag or paper towel be placed near the thermocouple vent hole to collect

the vented water and prevent it from running down inside the instrument or into the sensor cavity.

The test cell and instrument are now ready to begin a compressive strength test.

Running a Test

Pressure Control

This section describes how the Pump Regulator and Pressure Relief Valves work together for automatic pressure control.

As the test cell is heated, the pressure will increase. When the pressure exceeds the control pressure upper limit, the relief valve will open and pressure will be reduced. If the heating rate is reduced, as during the temperature transition from a ramp to a soak profile, the pressure in the test cell may begin to fall. If the pressure falls below the control pressure lower limit, the pump will stroke and bring the pressure back within the established limits.

The pump and relief valve will have a “dead band” or hysteresis in their operation. If the relief valve is set to relieve at 4000 psig, it may open at 4000 psig, but may not close until the pressure falls to, for example, 3900 psig. This 100 psig differential between opening and closing is called the “dead band” or hysteresis. As another example, the pump may be set to begin pumping if the pressure falls to 3000 psig, but the pressure may reach, for example, 3100 psig before the pump stops. This 100 psig differential between the start pressure and the stop pressure is also known as “dead band” or hysteresis. If the upper and lower set points are set too close together, this “dead band” may overlap and cause the system to go into a continuous oscillation where the pump tries to increase pressure and the relief valve releases all the pressure the pump is able to build. The solution to this problem is to decrease the lower set point or raise the upper set point or both.

Starting the Test

1. Turn the POWER switch to the ON position
2. Open the PRESSURE valve left/right on the cylinder to be pressured.
3. Turn the PUMP switch to the ON position and rotate the PUMP REGULATOR valve clockwise until the cylinder reaches the desired pressure set point. If the cylinder will not reach the pressure set point, turn the PRESSURE RELIEF valve clockwise until the cylinder develops the desired pressure.
4. Turn the PRESSURE RELIEF valve counterclockwise slowly until the test cell pressure begins to drop slightly below the set point. Continue turning the regulator knob slowly until the pressure in the test cell equals the upper limit of the desired test pressure.
5. Turn the HEATER switch to ON. (The heater and pump will not start until the program start up is initiated through the controller.)

6. To begin the test, the Temperature Controller program must be started by pressing the EZ1 button on the controller. The output “1” light should begin flashing indicating the control output to the heater and or pump.
7. The COOLANT switch should be OFF

Note: Turn the coolant control switch to AUTO if an external chiller is used.

Ending the Test

1. Turn the HEATER switch to the OFF position.
2. To end the test, turn the HEATER switch to the OFF position.
3. Turn the Temperature Controller OFF by pressing the Advance  button so that the controller displays CM.1 and pressing the up or down arrow buttons to select OFF.

Note: Always leave the controller in the OFF mode with the HEATER switch turned OFF when the thermocouple is not installed in the cylinder.

4. Turn the COOLANT switch left or right to the ON position to cool the test cell. Monitor the test cell temperature using the Temperature Controller. Use the pump to maintain pressure on the test cell until the cell is cool. When the temperature is below 200°F (93°C) the pump switch may be turned to the OFF position and the PRESSURE RELEASE valve opened. Failure to maintain pressure at temperatures above 212°F (100°C) may cause water in the test cell to become steam.
5. Turn PRESSURE Left/Right valve to the OPEN position (counterclockwise).
6. If no other test is running, turn the MAIN POWER switch to the OFF position.
7. Close the PRESSURE RELEASE valve (clockwise). Failure to do so will result in water leakage.
8. Remove the Quick Disconnect connector from the test cell.
9. Disconnect the sensor cable.
10. Remove the thermocouple or disconnect the cable.
11. Lift the test cell from the instrument assembly.

Cleaning the Test Cell

When the test cell has been cooled and removed from the instrument, it should be cleaned according the following guidelines.

1. Place the test cell in a vise, top side up. Use the wrench flats and do not scratch or nick the cylinder or plugs.
2. Remove the top plug and pour off any standing water on the cement sample.
3. Remove the cell from the vise and then replace the cell in the vise, top side down.

4. Unscrew and remove the bottom plug of the test cell.
5. Turn the cell over and tap the cement sample out of the test cell with a drift bar and a hammer.
6. Clean the cement and grease from the top and bottom plugs and cylinder with soap and water, or an appropriate solvent.
7. When all traces of cement have been removed, replace the O-rings. Grease the inner surfaces of the test cell, including the seal, O-rings, and threads with a liberal coating.

The unit is now ready to run another test.

This page is intentionally left blank.

Section 3 - Maintenance and Servicing

This chapter describes the basic maintenance that is required for the 4262A, B, and C Instruments. A troubleshooting guide is provided in the next section, in the event that problems occur.

Maintenance

The 4262 Ultrasonic Cement Analyzer requires very little routine maintenance. Following the recommendations listed below will allow years of trouble free operation.

- Keep all test cell surfaces exposed to cement coated with a liberal layer of grease. This reduces the chance of corrosion and prevents cement from adhering to the metal.
- Keep cement off threads and out of the high pressure ports on the top plug of the test cell.
- Lubricate the threads on the test cell plugs before every test with an anti-seize lubricant.
- Thoroughly clean test cell of all cement immediately after each test.
- Replace the O-rings after every test.
- Replace the inline water filter element every 3 months under normal use or every month under severe use with poor water quality.

7 Micron Filter Replacement

Open the rear panel on the back of the instrument. Locate the filter (item 30 on drawing 84-0007), remove the snap ring and filter housing cap. Remove the filter and replace with new filter part number C09872. Reassemble the filter housing cap and replace the snap ring.

Regulator Rebuild Instructions

Repair Kit Required: Chandler Part Number C09989

Refer to the figure at the end of this section.

Tools required: 5/16" Wide Screwdriver

1/2" Wide Screwdriver

1/2" Socket Wrench

1/2" Open End Wrench or Small Adjustable Wrench

1-3/4" Open End Wrench or Large Adjustable Wrench

Needle Nose Pliers

The regulator is readily disassembled from the front panel. All disassembly can be done WITHOUT removing the regulator from the instrument.

Major Disassembly

1. Ensure all pressure is released from the instrument.
2. Rotate the regulator knob (Item 159) fully counterclockwise to remove tension from the regulator assembly.
3. Remove the hole plug (Item 155) from the regulator knob using the narrow (5/16" wide screwdriver) to pry the hole plug free.
4. Unscrew the nut (Item 153) from inside the regulator knob cavity using the 1/2" socket wrench.
5. Unscrew the bonnet (Item 151) using the 1-3/4" open end wrench. The bonnet will come off as an assembly: Bonnet (Item 151), adjusting screw (Item 160), collar (Item 002), limit screw (Item 158) and load spring (Item 006).
6. Items 161 and 162 do not exist in the stainless steel design. The bonnet (Item 151) is a closed end component as shown in detail (A).
7. Remove the sensor assembly from the body (Item 001) using the needle nose pliers to grip and pull the sensor from the regulator body. A rocking motion may be required to free the sensor assembly.
8. Unscrew the seat retainer (Item 004) from the body Item (001) and remove the seat (Item 003).
9. Clean the seat retainer.
10. Replace the seat (Item 003). Place the beveled (chamfered) side of the seat facing out toward the sensor assembly stem. eg., The seat should have the chamfer facing into the seat retainer thus the chamfer will face out when retained in the regulator body.
11. Install the seat retainer with the seat back into the body. Use a small amount of anti-seize lubricant on the seat retainer threads.

Bonnet Disassembly/Reassembly

1. Remove the limit screw (Item 158) from the spring cap (Item 002)
2. Remove all components from the bonnet.
3. Clean and lubricate the bearing using a suitable lubricant.
4. Clean the spring cap and adjusting screw threads. Place a small amount of anti-seize lubricant on the threads.
5. Clean the spring
6. Reassemble the bonnet components. Install the limit screw.
7. Set the bonnet assembly aside for later installation.

Sensor Disassembly / Reassembly

1. Unscrew the spring pad (Item 105) from the sensor (Item 102) using the 1/2" open end wrench and the large 1/2" wide screwdriver. You may wish to clamp the spring pad in a vise to perform this step.

Caution: Small parts are present within the sensor assembly. Take care not to lose the parts.

2. Pull the spring pad away from the sensor. Retain the spacer (Item 106) for later use.

Caution: Small parts are present within the sensor assembly. Take care not to lose the parts.

3. Remove the sensor components: Valve Stem (Item 101), Spring (Item 104), Spacer (Item 106), Seal (Item 007) and Sensor backup (Item 103).
4. Remove and replace the backup rings and o-rings (Items 051, 053, 052 and 054) using the new seals from the rebuild kit. Lubricate the o-rings with a suitable lubricant.
5. Replace the sensor internal components using the new internal components; Valve Stem (Item 101), Spring (Item 104) and Seal (Item 007). Reuse and reinstall the original spacer (Item 106).
6. Reassemble the sensor pad, sensor backup and sensor. Place a small amount of anti-seize lubricant on the threads.
7. Discard all the used components.

Major Assembly

1. Place the sensor assembly back into the body (Item 001). Place a small amount of o-ring lubricant on the o-ring (Item 0052). Push the assembly into place using the needle nose pliers.
2. Screw the bonnet assembly with the spring into the body. Place a small amount of anti-seize lubricant on the threads.
3. Install the knob, nut and cover plug back on the regulator.

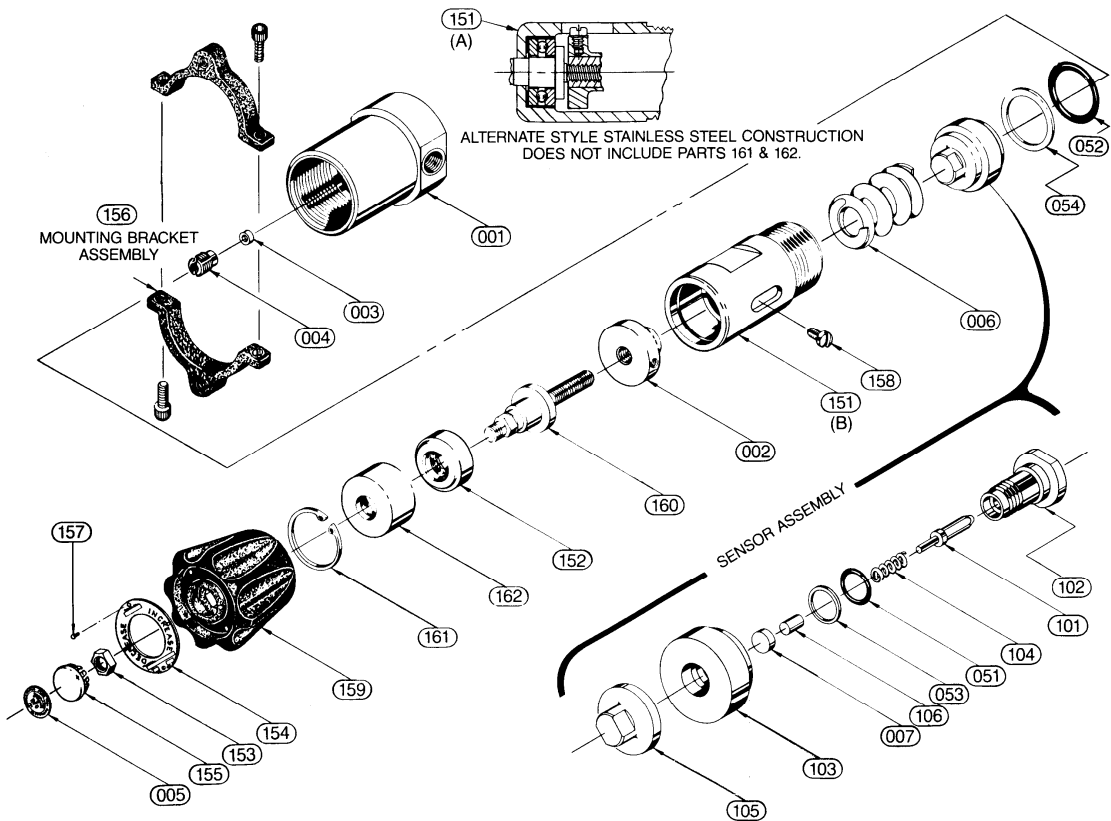

This page is intentionally left blank.

Section 4 - Troubleshooting Guide

The following table lists symptoms of several common problems, the possible cause of the problem, and the possible solution to the problem.

Symptom	Possible Cause	Possible Solution
MAIN POWER circuit-breaker switch trips off.	Short circuit in system wiring.	Disconnect power to instrument and check for short circuits with an ohm-meter.
	Faulty MAIN POWER switch.	Replace switch.
Temperature controller does not come on.	Loose connection in controller wiring	Disconnect power to instrument and check power connection on back of controller
	Faulty controller	Replace controller
	High temperature drop-out	Allow cell to cool below 375EF.
Instrument not receiving power.	Instrument not plugged in.	Connect instrument to the correct power source.
	Thrown breaker on circuit supplying power to the instrument.	Check breakers on electrical supply circuit.
Pump will not operate.	Insufficient air pressure to pump.	Check air supply and make certain instrument is supplied with air between 75 and 125 psig. Check air lines for blockage. Adjust PUMP PRESSURE ADJUST regulator to a higher pressure.
	Solenoid valve controlling flow of air to pump is not functioning.	If no solenoid click is heard when the PUMP switch is turned to the ON position, a faulty solenoid valve is likely.
Pump operates, but will not build pressure.	CYLINDER WATER valve is not open or water is not being supplied to the instrument.	Open CYLINDER WATER valve and check flow of water to the instrument.

Symptom	Possible Cause	Possible Solution
Pump operates, but will not build pressure.	High-pressure tubing or test cell has air in it.	Crack high-pressure thermocouple fitting and release any air trapped in the lines or cylinder.
	High-pressure tubing or test cell is leaking.	Check for water leakage and isolate leak.
	PRESSURE RELEASE valve not closed or is leaking.	Close valve or replace stem/seat, if necessary.
	Relief valve is not holding pressure.	Turn Relief valve knob clockwise.
	Relief valve is not holding pressure.	Debris may be trapped under relief valve seat. Turn relief valve knob counterclockwise all the way and turn pump ON for a few seconds to flush the debris off the seat.
	High pressure tubing blocked by cement.	Release pressure and clear tubing.
Large amounts of water leak from the pressure or thermocouple ports in the test cell when fittings are removed.	PRESSURE RELEASE valve is open.	Close PRESSURE RELEASE valve.
Temperature will not rise above ambient.	Solid State relay is defective.	Replace relay.
	HEATER switch not in the ON position.	Turn heater switch to ON position.
Temperature overshoots the soak value.	Temperature controller PROPORTIONAL BAND tuning parameter too low.	Increase proportional band using temperature controller tune loop.
	Temperature controller CUTBACK TIME tuning parameter too low.	Increase the cutback time using the temperature controller tune loop.

Symptom	Possible Cause	Possible Solution
Measured parameters display zero when they should not.	Loose wiring.	Find and repair loose connections.
	Incorrect or missing I/O module address in software.	Use the SCAN.EXE software to map each I/O channel and make certain the software is configured to agree with the existing addresses.
	Two I/O channels have the same address.	Use the SCAN.EXE software to configure each I/O channel to have a unique address.
SCAN.EXE does not detect all I/O channels.	Loose connection or blown fuse.	Check fuses and connections.
	RS-485 connections are wired improperly.	Check RS-485 wiring.
Transit time below 14.5 micro-sec/inch at start of test.	Electronics has locked on to the wrong signal	Reset affected channel.

This page is intentionally left blank.

Section 5 – Replacement Parts

Part Number	Description
8051-4262-E or -M	Controller, Temperature (English or Metric)
7750-0115	Handle, Top Plug
80-0035	Foam Centering Sleeve
80-0057	Calibration Bar - 3.500
80-0112-03	I/O Board Assembly
84-0012	Top Plug
84-0013	Bottom Plug
84-0015	Cylinder Support
84-0016	Cylinder Base
84-0045	Cylinder Assembly
84-0049	Heating/Cooling Coil
84-0050	Slurry Level Gauge
84-0065	O-Ring Back-up Ring
84-0107	T/C, Type “J”
85-0023-02	Cable Assembly, Top & Bottom
C08106	Switch, Toggle, DPST
C08439	Computer Cable, 25P - 25S
C08564	Retaining Ring
C08565	O-Ring, Viton
C08571	Couplant, High Temp, 2 oz.
C08572	Thermostat, 420 Open/380 Close
C08583	Insulation, Fibrous Glass, .50 x 60
C08584	Transducer
C08587	Adapter, BNC, Male-Male
C08725	Computer Cable, 25P - 9S
C09111	Valve, SS, 1/4T-1/4T, Needle
C09163	Valve, Solenoid, 220V (Cooling)
C09211	Gauge, Pressure, 6000 psi
C09215	Regulator, Back Pressure
C09263	Seal Kit, Air Drive

5-2 SECTION 5 – REPLACEMENT PARTS

Part Number	Description
C09298	Filter, 7 Micron, Tee
C09366	Pump
C09872	Replacement Filter, 7 Micron
C09890	Filter, In-line, 60 Micron
C10229	Wrench, 5/8" Combination
C10961	Seal Kit, Hydraulic Section
P-1254	Fitting, 1/4 MPT x 1/4T
P-3107	Valve, Solenoid, 220V (Air)
P-3387	Switch, On/Off Circuit Breaker, 16A

Section 6 - Drawings and Schematics

Drawing Number	Drawing Title
84-0004	Interconnect Wiring
84-0006	Rear Connections
84-0007	Piping Diagram
84-0045	Assembly, Dual UCA Cylinder
84-0046	Front Panel Layout
84-0057	High Temp Cable Assembly
84-0103	Wiring Diagram

REVISIONS				
ZONE	REV	DESCRIPTION	DATE	APPROVED
B	1	EDN T5766; REMOVE C0B464 FROM BOM	2/14/14	TC

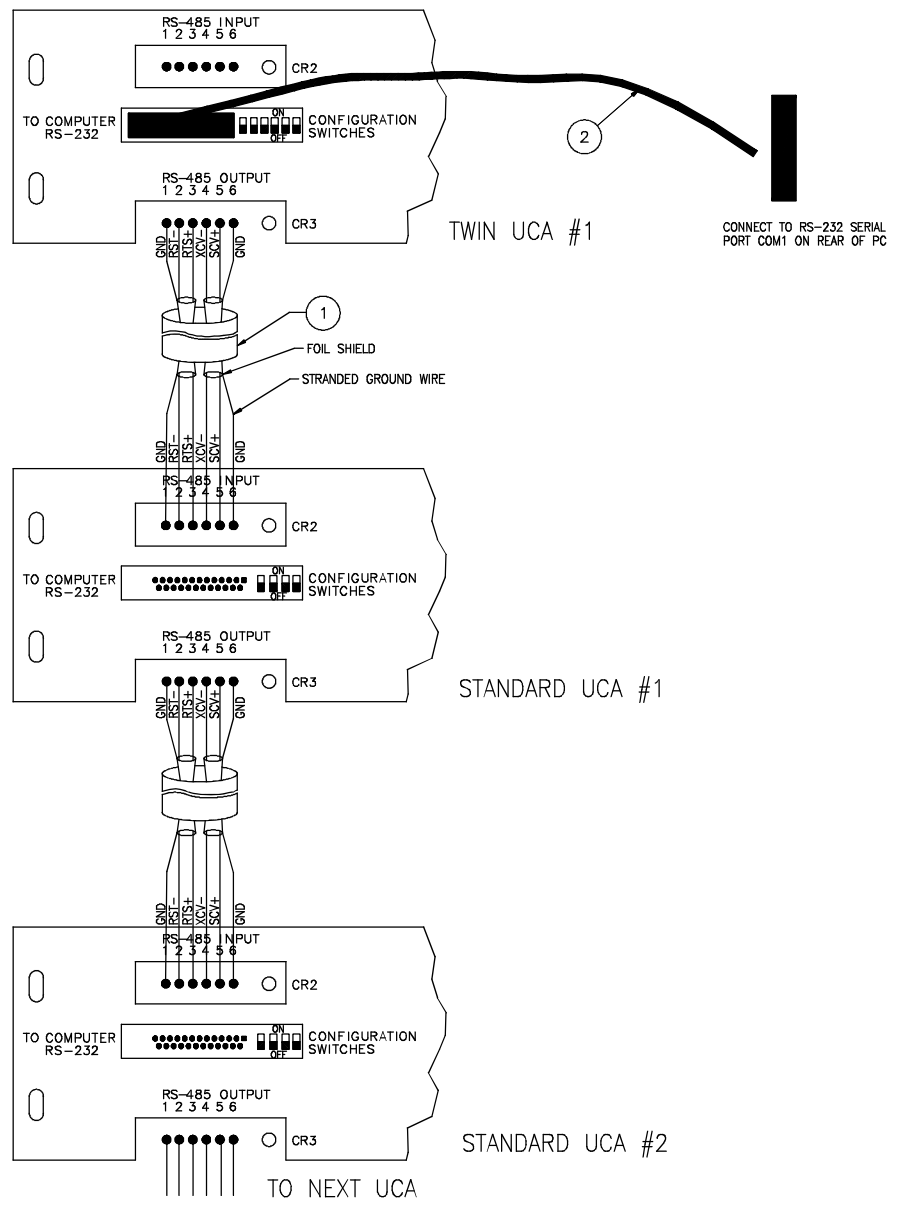

CONFIGURATION SWITCH SETTINGS

FUNCTION	SW1	SW2	SW3	SW4	SW5	SW6
NORMAL OPERATION	OFF	OFF	OFF	OFF	OFF	OFF
CONFIGURE LEFT TEMPERATURE	ON	OFF	OFF	OFF	OFF	OFF
CONFIGURE LEFT PRESSURE	OFF	ON	OFF	OFF	OFF	OFF
CONFIGURE RIGHT TEMPERATURE	OFF	OFF	ON	OFF	OFF	OFF
CONFIGURE RIGHT PRESSURE	OFF	OFF	OFF	ON	OFF	OFF
CONFIGURE TRANSIT TIME	OFF	OFF	OFF	OFF	ON	OFF

2	1	C0B439	RS-232 SERIAL CABLE
1			
ITEM	QTY	NUMBER	DESCRIPTION
PART LIST			

UNLESS OTHERWISE SPECIFIED DIMENSIONS IN INCHES (mm)		CHANDLER ENGINEERING			
TOLERANCES:					
1 PLACE	+0.030 [-76]				
2 PLACE	+0.010 [-25]	TITLE			
3 PLACE	+0.006 [-127]	INTERCONNECT WIRING			
ANGLES	1/2°	TWIN UCA			
SURF. FINISH		SIZE			
APPLICATION	USED ON	S.D. NO.	DWG NO.	REV.	
		A4	B4-0004	B	
<small>This document and the drawings and technical data contained herein are the property of Chandler Engineering Company LLC. Reproduction or distribution in any form without the written consent of the owner is forbidden. The holder agrees to return this document to the owner on demand.</small> <small>Copyright by Chandler Engineering Company LLC</small>		SCALE:	1 = 1	DO NOT SCALE DRAWING	SHEET: 1 of 1

DO NOT ATTEMPT TO CHANGE THE CONFIGURATION WITHOUT FIRST READING THE INSTRUCTION MANUAL!

REVISIONS				
ZONE	REV	DESCRIPTION	DATE	APPROVED
	C	ECN# 7660	02/08/02	JAC/JH
	D	ECN# 7670, REARRANGE FITTINGS	03/22/02	JAC/TC

Installation With Chiller

Installation Without Chiller

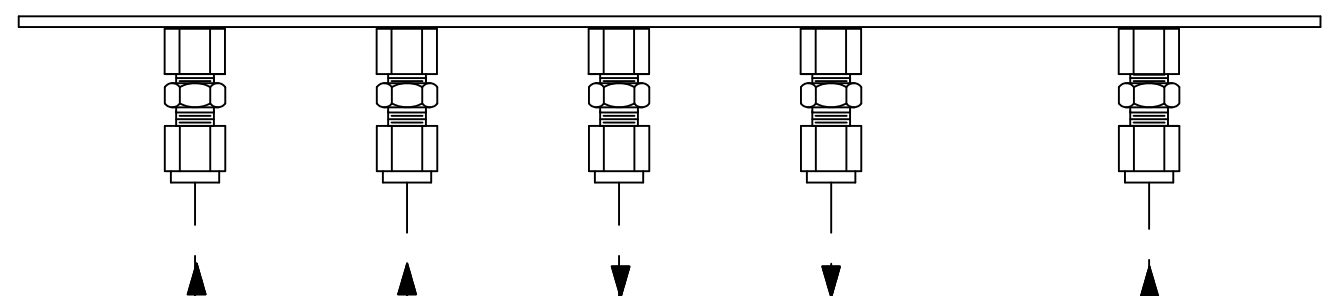
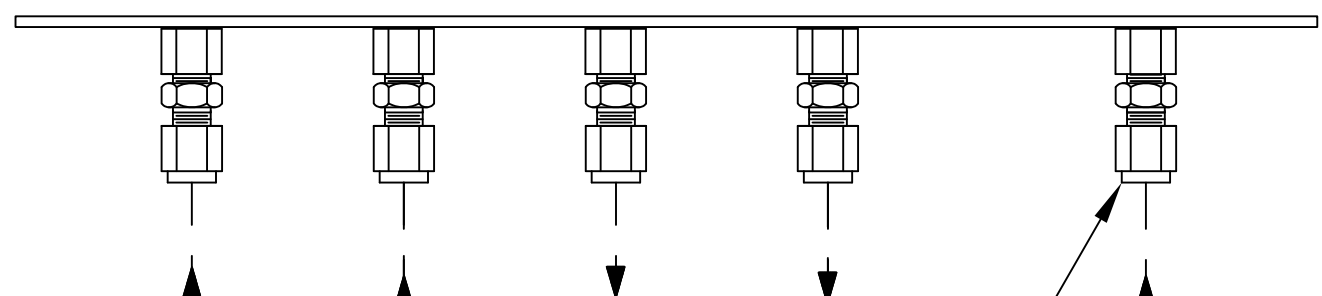
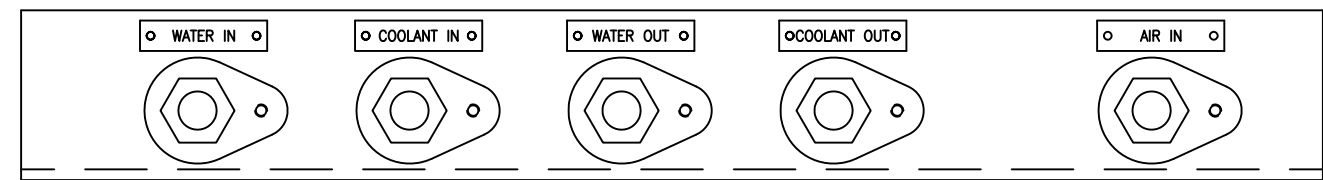
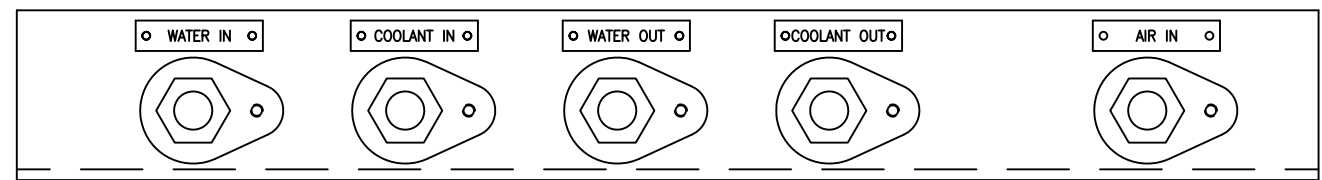

From Water Supply

From Chiller

To Drain

To Chiller

From Air Supply

From Air Supply

Connector,
1/4 Tube X 1/4 Male Pipe

Tee, 1/4 Tube (2)

From Water Supply

To Drain

UNLESS OTHERWISE SPECIFIED DIMENSIONS IN INCHES [mm]		CHANDLER ENGINEERING		
TOLERANCES:				
1 PLACE	+0.030 [.76]	REAR CONNECTIONS		A
2 PLACE	+0.010 [.25]	TWIN ULTRASONIC CEMENT ANALYZER		
3 PLACE	+0.005 [.127]	APPROVALS		
ANGLES	±1/2°	DATE		
SURF. FINISH 32		DRAWN: <i>AEB</i> 10/08/98		SIZE
NEXT ASSY		CHECKED: <i>PTL</i> 10/08/98		S.O. NO.
USED ON		ENGR.: <i>PTL</i> 10/08/98		DWG NO.
APPLICATION		SCALE: 1 = 1		DO NOT SCALE DRAWING
This document and the drawings and technical data contained herein are the property of Chandler Engineering Company LLC. Reproduction or dissemination in any form except as expressly authorized by the owner is forbidden. The holder agrees to return this document to the owner on demand.		Copyright by Chandler Engineering Company LLC		SHEET: 1 of 1

ITEM NO.	PART NUMBER	DESCRIPTION	-01	-02
1	P-1954	FITTING, SWAGelok, B-400-71-4	5	5
2	P-1265	TEE,BRS,UN,1/4TX1/4TX1/4T,SW	3	3
3	P-1255	ELBOW,BRS,1/4MPX1/4T,SW	9	9
4	P-3107	VAL,SOL,SS,1/4F,2WY,240VAC	1	1
5	P-0866	BUSHG,BRS,RDCG,1/4FPX3/8MP UB	1	1
6	C09163	VALVE,SOL,SS,1/4F,2WY,240VAC	2	2
7	P-1246	ELBOW,BRS,1/8MNP1X1/4T	2	2
8	C05973	ELBOW,SS,1/4FPX1/4MP	2	2
9	84-0113	ASSY, U-TUBE	2	2
10	C09352	STEM,SS,QDISC,1/4X1/4OD,SW	4	4
11	C09366	PUMP,6150 PSI, 3L-SS-41	1	1
12	C09351	CPLG,SS,QDISC,1/4X1/4	REF	REF
13	R-0631	SS,TBG,0.250ODX0.036W,316	REF	REF
14	P-1887	REG,PRESS,300/100PSI,1/8 FP	1	1
15	C09211	GAGE,6000PSI,2.5",1/4NPT,SS,CBM	3	3
16	C08517	CONN,SS,1/4FPX1/8T,SW	3	3
17	C08361	CROSS,SS,1/8T	3	3
18	70607-85	TEE,SS,UN,HP,1/8TX1/8TX1/8T	2	4
19	C09367	VALVE,NDL,SS,1/8X1/8,ANG,SW	2	2
20	187-20404	ELBOW,SS,1/8TX1/4MP,SW	2	2
21	84-0108	VALVE,RLF,SS,1/4TX1/4T,6000PSI	2	2
22				
23	P-1277	CROSS,BRS,UN,1/4T,SW	1	1
24	C09215	REG,BACK,50-6KSI	1	1
25	R-0125	COPPER,TBG,0.250OD	11'	11'
26	R-0645	SS,TBG,0.125ODX0.036W,316	10'	10'
27				
28	C09891	FILTER,INLINE,60 MICRON	1	1
29				
30	C09298	FILTER,TEE,SS,7 MICRON,1/8T	1	1
31	P-1944	REDUCER,SST,1/8TX1/4OD SW	5	8
32	C07428	UNION,BR,BHD,1/4TX1/4T,SW	3	3
33	C08970	TRANSDUCER	0	2
34	C09283	CONN,SS,1/4FPX1/4T,BHD,SW	2	2
35	C09111	VALVE,NDL,SST,1/4TX1/4T ANG SW	1	1
36	84-0049-R	COOLING COIL	1	1
37	84-0009-L	COILING COIL	1	1
38	84-0030	CABINET,4262A	REF	REF
39				
40	C09705	CONN,PORT,1/8	6	6
41	84-0116-02	TUBE,RELIEF VALVE TO CROSS,HP	REF	REF
42	84-0116-03	TUBE,CROSS TO CYL,HP	REF	REF
43	84-0116-04	TUBE,RIGHT CYL. VALVE TO CROSS,HP	REF	REF
44	84-0116-05	TUBE,LEFT CYL. VALVE TO CROSS,HP	REF	REF
45	84-0116-07	TUBE,PRESSURE RELEASE TO TEE,HP	REF	REF
46	84-0116-08	TUBE,PUMP PRESS. VALVE TO CROSS,HP	REF	REF
47				
48	84-0116-10	TUBE,RIGHT CYL. VALVE TO CROSS,HP	REF	REF
49	84-0116-11	TUBE,PUMP TO TEE,HP	REF	REF
50	84-0117-01	TUBE,FILTER TO PUMP,LP	REF	REF
51	84-0117-02	TUBE,COOLANT OUT,LP	REF	REF
52	84-0117-03	TUBE,2 WAY VALVE TO LEFT CYL,LP	REF	REF
53				
54	84-0117-05	TUBE,WATER OUT,LP	REF	REF
55	84-0117-06	TUBE,COOLANT IN TEE TO 2 WAY VALVE,LP	REF	REF
56	84-0117-07	TUBE,PUMP REGULATOR TO PUMP,LP	REF	REF
57	84-0117-08	TUBE,PUMP REG. TO SOL. VALVE,LP	REF	REF
58	84-0117-09	TUBE,COOLANT IN,LP	REF	REF
59	84-0117-10	TUBE,2 WAY VALVE TO RIGHT CYL.,LP	REF	REF
60	84-0117-11	TUBE,AIR IN TO SOL. VALVE,LP	REF	REF
61	84-0117-12	TUBE,PRESSURE RELEASE TO TEE,LP	REF	REF
62	84-0117-13	TUBE,TEE TO CROSS,LP	REF	REF
63	84-0117-14	TUBE,RIGHT RELIEF VALVE TO CROSS,LP	REF	REF
64	84-0117-15	TUBE,LEFT RELIEF VALVE TO CROSS,LP	REF	REF
65	84-0117-16	TUBE,CONNECTOR,SHORT,LP	REF	REF
66	84-0117-17	TUBE,CONNECTOR,SHORT,LP	REF	REF
67	84-0117-18	TUBE,CONNECTOR,SHORT,LP	REF	REF
68	84-0116-06	TUBE,CONNECTOR,SHORT,HP	REF	REF
73	84-0052	PANEL,FRONT,DUAL UCA	REF	REF
74	84-0117-19	TUBE,PRESSURE RELEASE TO TEE,LP	REF	REF
75	84-0116-12	TUBE,PRESSURE RELIEF TO FILTER,HP	REF	REF
77	84-0116	TUBE SET,4262,HP	1	1
78	84-0117	TUBE SET,4262,LP	1	1

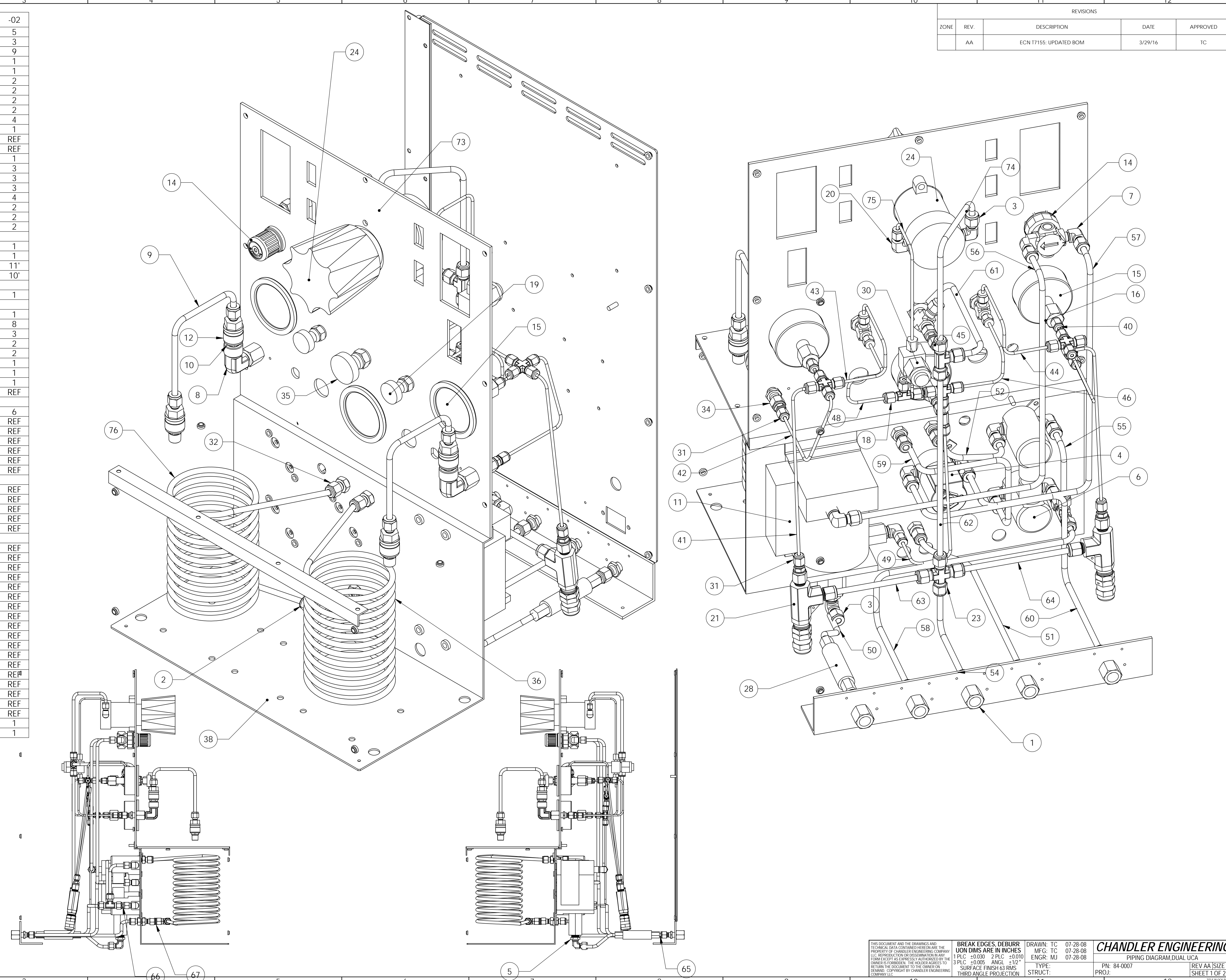

REVISIONS				
ZONE	REV.	DESCRIPTION	DATE	APPROVED
AA		ECN I7155: UPDATED BOM	3/29/16	TC

THIS DOCUMENT AND THE DRAWINGS AND TECHNICAL DATA CONTAINED HEREIN ARE THE PROPERTY OF CHANDLER ENGINEERING COMPANY. NO REPRODUCTION OR DISSEMINATION IN ANY FORM IS PERMITTED WITHOUT THE EXPRESS WRITTEN PERMISSION OF CHANDLER ENGINEERING COMPANY. THE USER AGREES TO RETURN THIS DOCUMENT TO THE OWNER ON DEMAND. COPYRIGHT BY CHANDLER ENGINEERING COMPANY, LLC.

BREAK EDGES, DEBURR
 UN DIMS ARE IN INCHES
 1 PLC ±0.030 2 PLC ±0.010
 3 PLC ±0.005 ANGLE ±12°
 SURFACE FINISH 63 RMS
 THIRD ANGLE PROJECTION

DRAWN: TC 07-28-08
 MFG: TC 07-28-08
 ENGR: MJ 07-28-08
 TYPE:
 STRUCT:

CHANDLER ENGINEERING
 PIPING DIAGRAM, DUAL UCA

PN: 84-0007
 PROJ:
 REV AA [SIZE D]
 SHEET 1 OF 2

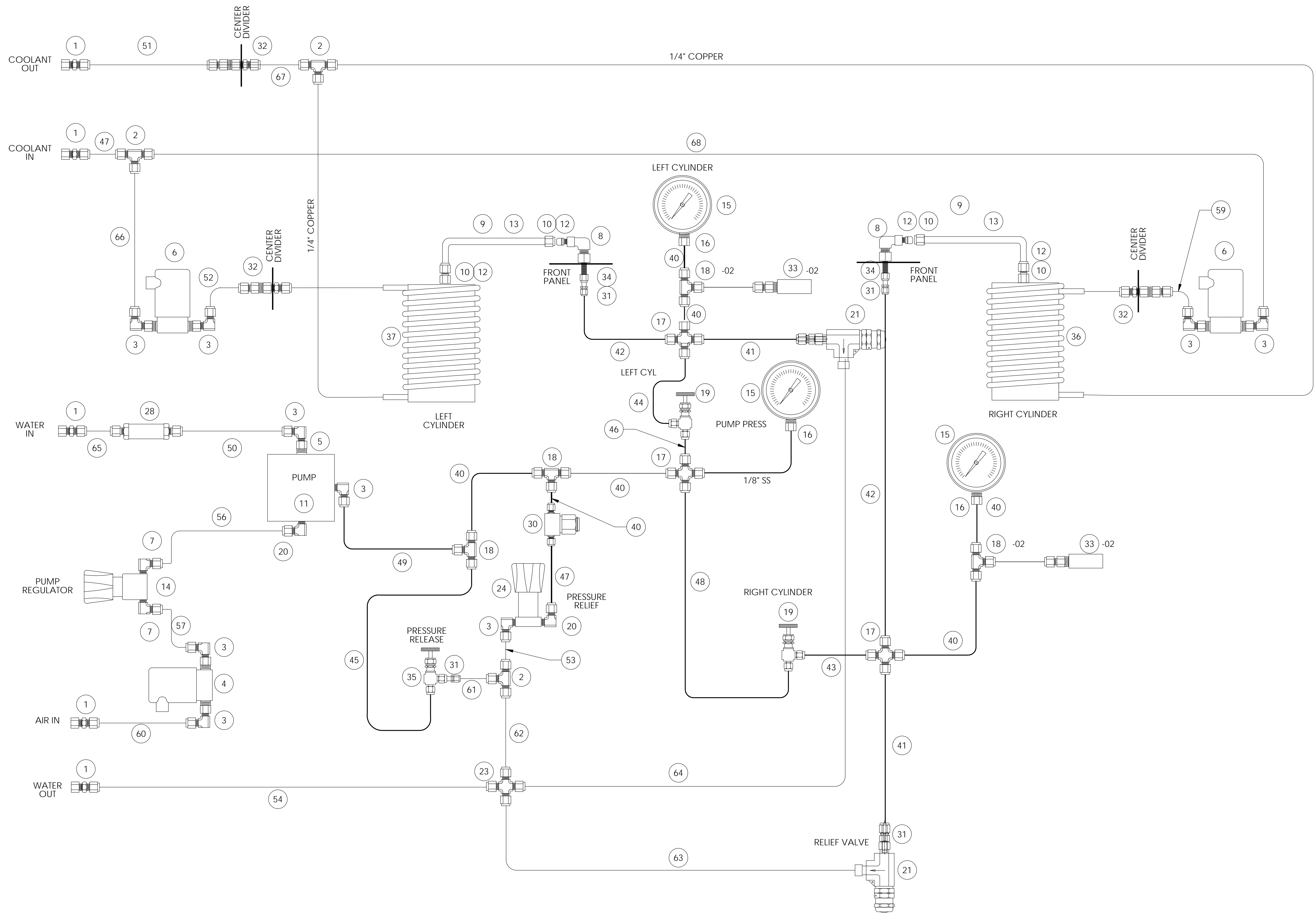

<small>THIS DOCUMENT AND THE DRAWINGS AND TECHNICAL DATA CONTAINED HEREON ARE THE PROPERTY OF CHANDLER ENGINEERING COMPANY. NO REPRODUCTION OR DISSEMINATION IN ANY FORM EXCEPT AS EXPRESSLY AUTHORIZED BY THE OWNER IS FORBIDDEN. THE USER AGREES TO RETURN THE DOCUMENT TO THE OWNER ON DEMAND. COPYRIGHT BY CHANDLER ENGINEERING COMPANY, LLC.</small>	BREAK EDGES, DEBURR UN DIMS ARE IN INCHES 1 PLC ±0.030 2 PLC ±0.010 3 PLC ±0.005 ANGL ±1.2° SURFACE FINISH 63 RMS THIRD ANGLE PROJECTION	DRAWN: TC 07-28-08 MFG: TC 07-28-08 ENGR: MJ 07-28-08 TYPE: STRUCT:	CHANDLER ENGINEERING PIPING DIAGRAM, DUAL, USA PN: 84-0007 PROJ:	REV AA [SIZE D] SHEET 2 OF 2 <small>TITLE BLOCK REV 1</small>
	<small>11</small>		<small>12</small>	
	<small>10</small>		<small>9</small>	

NOTES:

1. ADD LITHIUM GREASE (P-3217) TO O-RING AREA OF BOTH PLUGS PRIOR TO ASSEMBLY.
2. AFTER PRESSURE TEST IS COMPLETE, CYLINDER SHOULD BE RINSED OUT WITH SOLVENT AND WIPED DRY WITH RAG.
3. LITHIUM GREASE (P-3217) SHOULD BE REAPPLIED TO O-RING AREA AND CYLINDER SHOULD BE RE-ASSEMBLED.
4. CYLINDERS SHOULD BE PRESSURE TESTED, THEN FUNCTIONALLY TESTED.
5. PACKAGE USING BOX C12549.

REVISIONS				
ZONE	REV	DESCRIPTION OF REVISION	DATE	APPROVALS
	K	ECN T1563, ADDED NOTES 2, 3 AND 4	3/26/08	JB TC
	L	ECN T1824, ADDED NOTES 5	8/14/08	TC TC

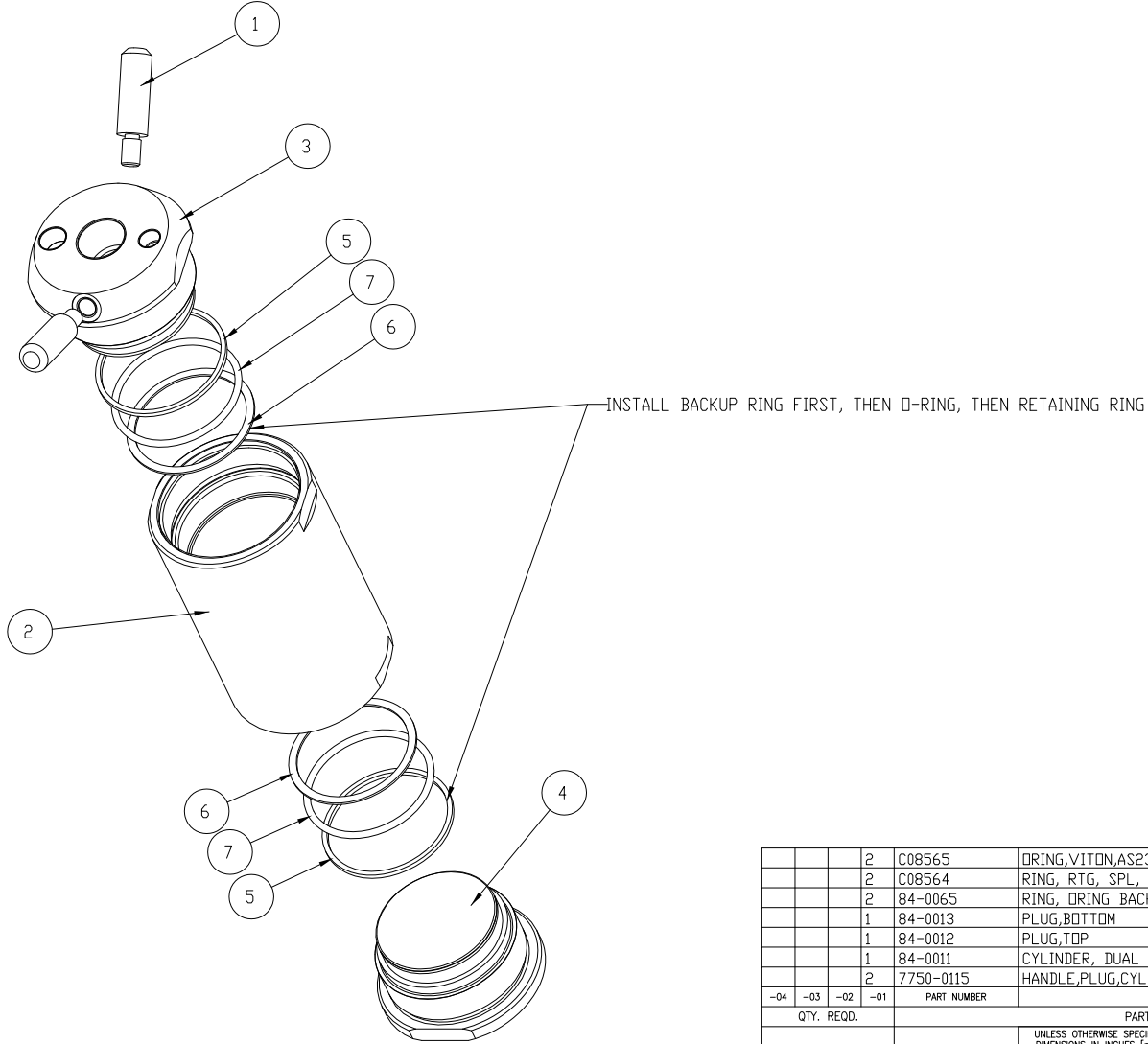

QTY.	REQD.	REVISION	PART NUMBER	DESCRIPTION	MATERIAL SPEC.	ITEM
		2	C08565	DRING,VITON,AS230-90		7
		2	C08564	RING, RTG, SPL, RS-250-EXT		6
		2	84-0065	RING, DRING BACK-UP		5
		1	84-0013	PLUG,BOTTOM		4
		1	84-0012	PLUG, TOP		3
		1	84-0011	CYLINDER, DUAL UCA		2
		2	7750-0115	HANDLE, PLUG, CYLINDER		1

QTY. REQD.		PARTS LIST		UNLESS OTHERWISE SPECIFIED DIMENSIONS IN INCHES [mm]		TOLERANCES:		CHANDLER ENGINEERING	
				1 PLACE	+0.030 (.76)			TITLE ASSY, TWIN UCA CYLINDER	
				2 PLACE	+0.010 (.25)				
				3 PLACE	+0.005 (.127)				
				ANGLES	±1/2°				
				SURF. FINISH	63/				
				APPROVALS	DATE				
				BREAK SHARP EDGES, DEBURR					

This document and the drawings and technical data contained hereon are the property of Chandler Engineering Company LLC. Reproduction or dissemination in any form except as expressly authorized by the owner is forbidden. The holder agrees to return this document to the owner on demand.				DRAWN: <u>0977</u> 9/17/99 CHECKED: <u>0977</u> 9/17/99 ENGR.: <u>0977</u> 9/17/99	SIZE: C SCALE: 1 = 1	S.O. NO. DWG NO. 84-0045	REV. L TITLE BLOCK REV: 1.0 SHEET: 1 of 1
--	--	--	--	--	-------------------------	-----------------------------	---

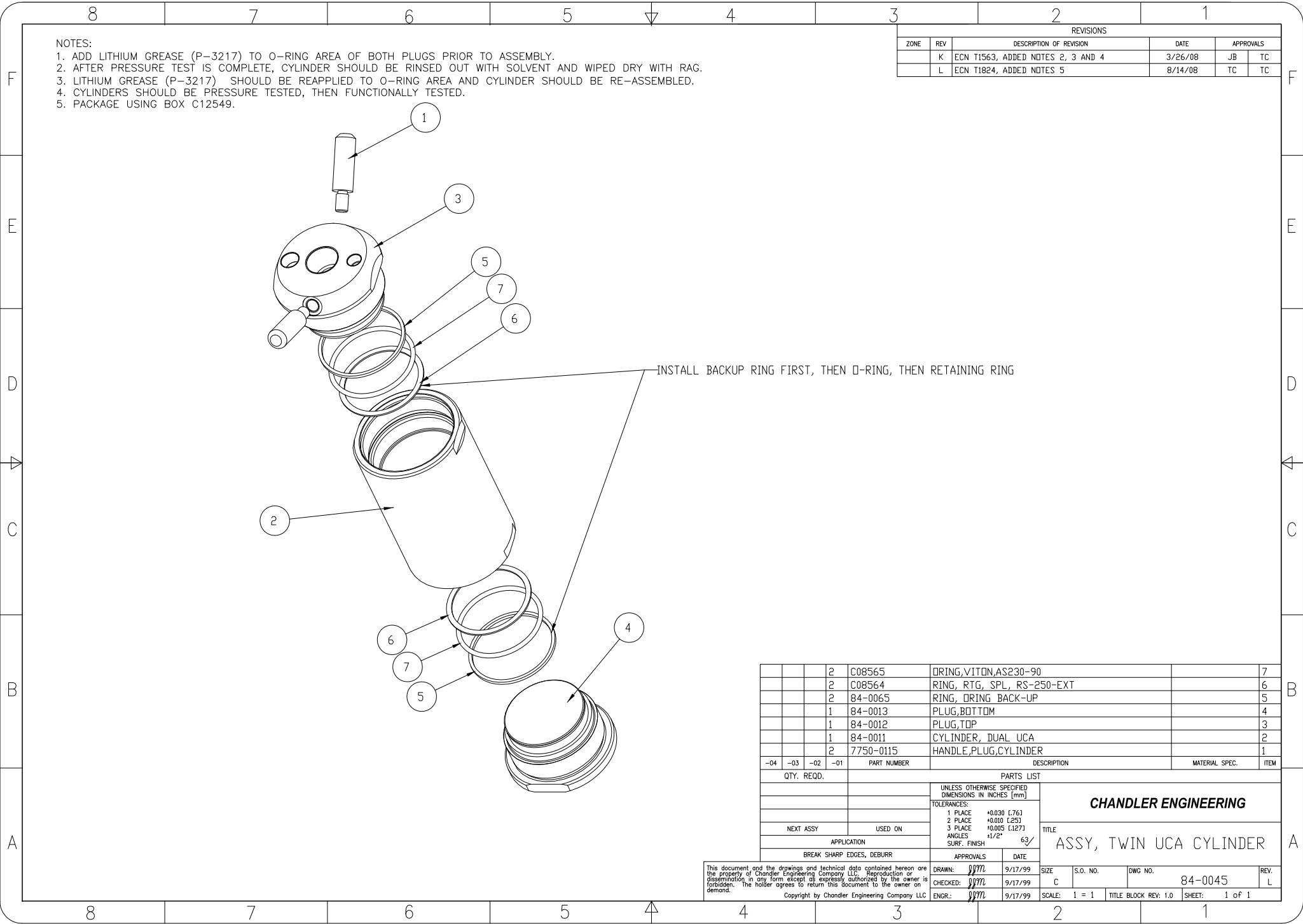

REVISIONS				
ZONE	REV	DESCRIPTION	DATE	APPROVED
C	ECN 7995		2/24/04	JC/BD
F9	D	ECN T1093, REMOVED KEY PAD	8/14/07	JB/TC
	E	ECN T5378; CHANGED TO WATLOW CONTROLLERS	6/13/13	TRB

PANEL IDENTIFICATION

1. CONTROLLER, TEMPERATURE, RIGHT/LEFT
2. SWITCH, HEATER, RIGHT/LEFT
3. SWITCH, COOLANT, RIGHT/LEFT
- 4.
5. SWITCH, POWER
6. PRESSURE RELIEF VALVE
7. PUMP PRESSURE ADJUST REGULATOR
8. PRESSURE VALVE, RIGHT
9. SWITCH, PUMP
10. PRESSURE VALVE, LEFT
11. PRESSURE RELEASE VALVE
12. PRESSURE PORT, RIGHT
13. TRANSDUCER CONNECTOR, RIGHT
14. CONNECTOR, THERMOCOUPLE, RIGHT
15. PRESSURE GAUGE, RIGHT
16. PRESSURE GAUGE, PUMP
17. PRESSURE GAUGE, LEFT
18. CONNECTOR, THERMOCOUPLE, LEFT
19. TRANSDUCER CONNECTOR, LEFT
20. PRESSURE PORT, LEFT

		UNLESS OTHERWISE SPECIFIED DIMENSIONS IN INCHES [mm]		CHANDLER ENGINEERING	
		TOLERANCES: 1 PLACE +0.030 [.76] 2 PLACE +0.010 [.25] 3 PLACE +0.005 [.127] ANGLES 1/2° 32/			
APPLICATION	USED ON	APPROVALS	DATE	TITLE	PANEL ID
BREAK SHARP EDGES, DEBURR					
DRAWN: AEB 01/26/98		SIZE	S.O. NO.	DWG NO.	REV.
CHECKED: JMD		D		84-0046	E
ENGR.: JMD		SCALE: 1 = 1	TITLE BLOCK REV: 1.0	SHEET: 1 of 1	

This document and the drawings and technical data contained hereon are the property of Chandler Engineering Company LLC. Reproduction or dissemination in any form except as expressly authorized by the owner is forbidden. The holder agrees to return this document to the owner on demand.

Copyright by Chandler Engineering Company LLC

8

7

6

5

↓

4

3

2

1

F

F

E

E

D

D

C

C

B

B

A

A

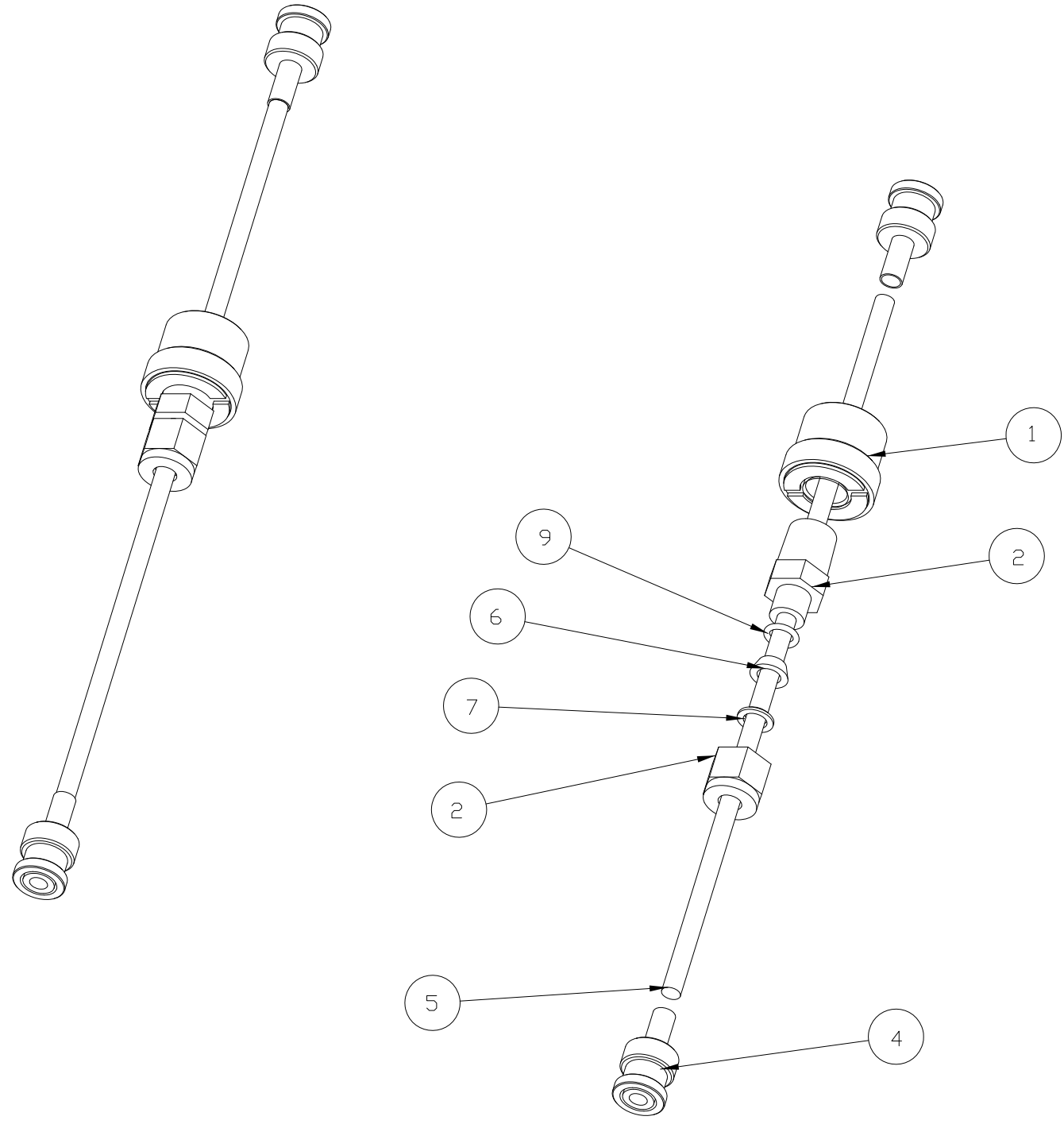

REVISIONS				
ZONE	REV	DESCRIPTION	DATE	APPROVED
	A	ISSUED	3/16/99	JJM
	B	[6590] UPDATED	01/10/00	JJM
	C	[6696]; CHANGED ITEM 5	06/06/00	AMW/JH
	D	[7266]; REMOVED SPRING	02/15/01	AMW/BD

QTY	QTY	QTY	QTY	PART NUMBER	DESCRIPTION	MAT'L SPEC	ITEM
			1	P-0061	O-RING		9
							8
			1	C09033	FERRULE, BACK, TFE		7
			1	C09032	FERRULE, FRONT, TFE		6
			1	C09035	CABLE, COAXIAL, 8.5"L		5
			2	C08578	CONNECTOR, BNC		4
							3
			1	84-0061	FITTING, CABLE		2
			1	84-0027	SLEEVE, TOP CONNECTOR		1
-03	-02	-01		PART NUMBER	DESCRIPTION	MAT'L SPEC	ITEM
QUANTITY REQ'D				PARTS LIST			

84-0045		MODEL 4262		UNLESS OTHERWISE SPECIFIED, DIMENSIONS IN INCHES [mm]		CHANDLER ENGINEERING	
NEXT ASS'Y		USED ON		TOLERANCES:			
APPLICATION		APPROVAL		DATE		TITLE	
		DRN: JJM		16-Mar-99		ASS'Y, CABLE, HIGH TEMP	
		CHK: JJM		16-Mar-99		SIZE DWG NO.	
		ENG: JJM		16-Mar-99		A2 84-0057	
						REV. D	
						SCALE: 1.000 SHEET 1 OF 1	

This document and the drawings and technical data contained hereon are the property of Chandler Engineering Co., LLC. Reproduction or dissemination in any form except as expressly authorized by the owner is forbidden. The holder agrees to return this document to the owner on demand.
Copyright by Chandler Engineering Co., LLC.

8

7

6

5

↑

4

3

2

1

REVISIONS				
ZONE	REV	DESCRIPTION	DATE	APPROVED
	Z	ECN T5378; CHANGED TO WATLOW CONTROLLERS	6/13/13	TRB
	AA	ECN T5484; CORRECTED WIRING FROM SSRS TO CNTRLRS 8/14/13		TRB

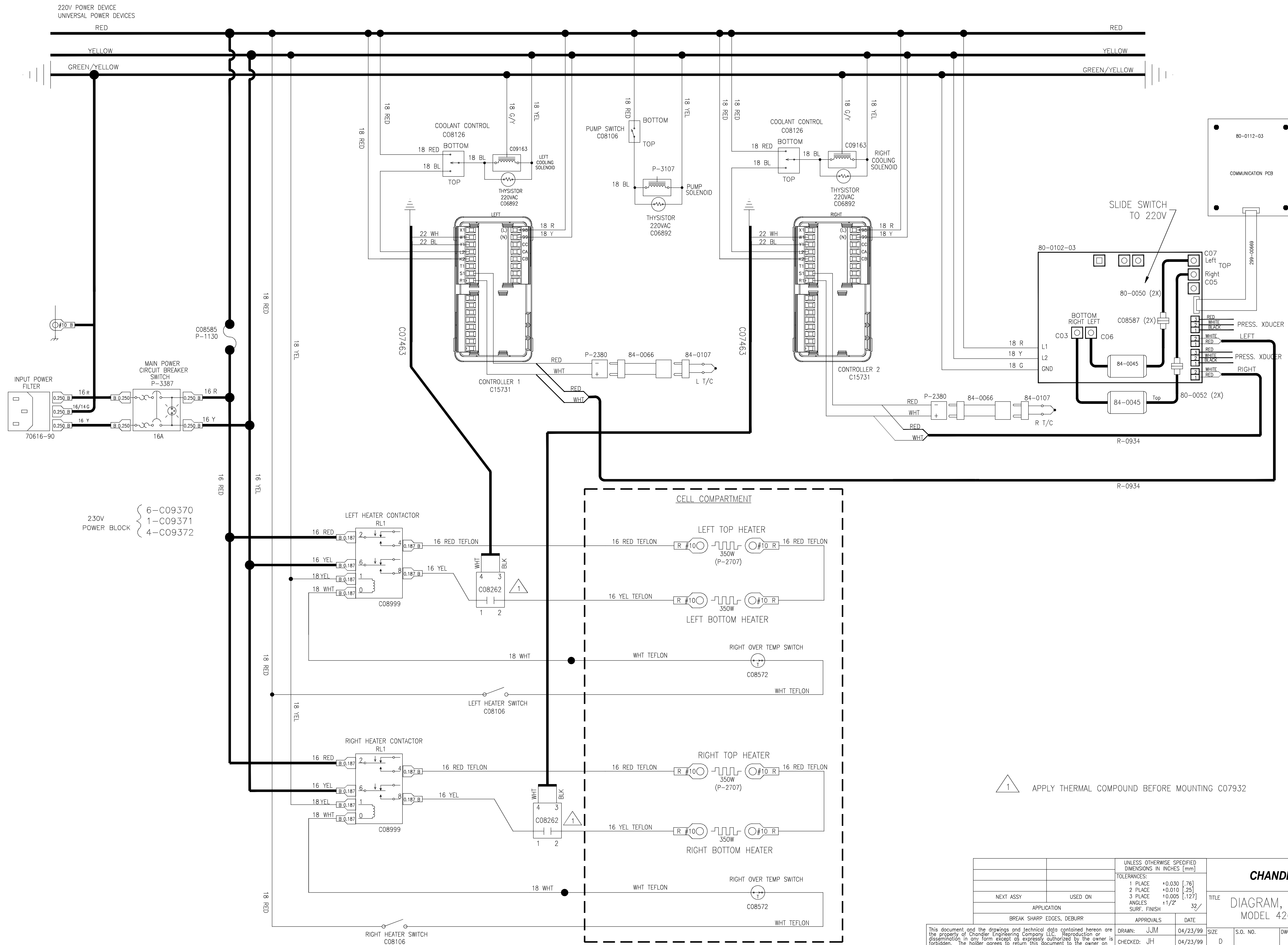

230V
POWER BLOCK

- 6-C09370
- 1-C09371
- 4-C09372

1 APPLY THERMAL COMPOUND BEFORE MOUNTING C07932

UNLESS OTHERWISE SPECIFIED DIMENSIONS IN INCHES [mm]		TOLERANCES:		APPROVALS		DATE	
1 PLACE	+0.030 [-.76]	DRAWN:	JJM	04/23/99	SIZE	D	S.O. NO.
2 PLACE	+0.010 [.25]	CHECKED:	JH	04/23/99	ENGR.:	JJM	06/24/99
3 PLACE	+0.005 [.127]	APPLICATION		BREAK SHARP EDGES, DEBURR		SCALE: 1 = 1	
ANGLES	+1/2°	SURF. FINISH		32/		TITLE BLOCK REV: 1.0	

CHANDLER ENGINEERING

TITLE: **DIAGRAM, WIRING, 220VAC MODEL 4262 TWIN CELL UCA**

This document and the drawings and technical data contained herein are the property of Chandler Engineering Company LLC. Reproduction or dissemination in any form except as expressly authorized by the owner is forbidden. The holder agrees to return this document to the owner on demand.
Copyright by Chandler Engineering Company LLC

REV. AA
84-0103
SHEET: 1 of 1